

JSIR 350-4 HermeSEAL[®] technology

The hermetic cap allows new applications in harsh environments – such as high temperature, high partial gas pressure and high humidity.



Features

- Increased lifetime by reduction of oxidation processes
- Backfilling with different gases possible on request
- High safety level for explosion proof applications
- Ideal for battery or stand-alone applications with low power supplies*
- Long-term stable

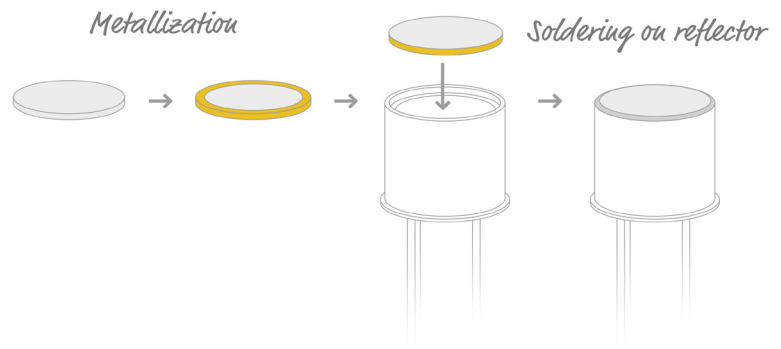

Additional product information

By soldering a metalized filter on the reflector or cap Micro-Hybrid's infrared sources perform high efficient* and long term stable. This new technology effects IR components to be impenetrable to gases. The components do not show any permeation of water vapor or (environmental) gases compared to glued elements.

The spectral behavior can be individually adapted by various windows. Technical parameters such as time constant and power consumption can be adjusted with

different filling gases. The innovative filter and window elements can be customized in size and optical coating according to customer specifications. This innovation represents a huge potential of improvement in the field of NDIR gas analysis.

*by using thermal insulating backfill gases or variation of modulation frequency

Online shop for IR components and sensors

Filter products simply by selecting the desired properties and request your quotation.

 microhybrid.com/shop



Technical data

Technical parameter	Window N ₂	Unit
Spectral output range	2 ... 15	μm
Active area	2.2 x 2.2	mm ²
Hot resistant ¹	40 ± 20	Ω
Temperature coefficient ²	typ. 500	ppm/K
Time constant _{0-63 %}	typ. 12.5	ms
Nominal power consumption ³	650	mW
Operation voltage ⁴	4.9	V
Operation current ⁴	132	mA
Recommended driving mode	Power mode	
Active area temperature ^{1,5,6}	610 ± 30	°C
Window	Si ARC, Sapphire	
Housing	TO39	
Estimated lifetime ^{7,8}	> 5 000 h at 740 °C	
	> 100 000 h at 610 °C	
Absolute max. ratings		
Input power ^{3,5}	1 200	mW
Housing temperature ⁸	125 with Si ARC window 185 with Sapphire window	°C
Active area temperature	850	°C

¹ At nominal power

² 25 °C - 800 °C

³ At power on-state

⁴ With 40 Ω hot resistant

⁵ At T_{amb} = 25 °C

⁶ Mean of temperature distribution with 10 % decrease of hotspot temperature measured by IR camera (0.7-1.1μm)

⁷ Continuous mode, MTTF 63 % (membrane fracture, calculated values based on Arrhenius)

⁸ Including ambient temperature

Typical operating characteristics

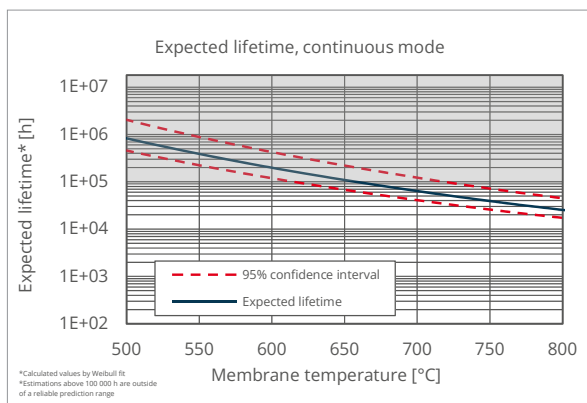
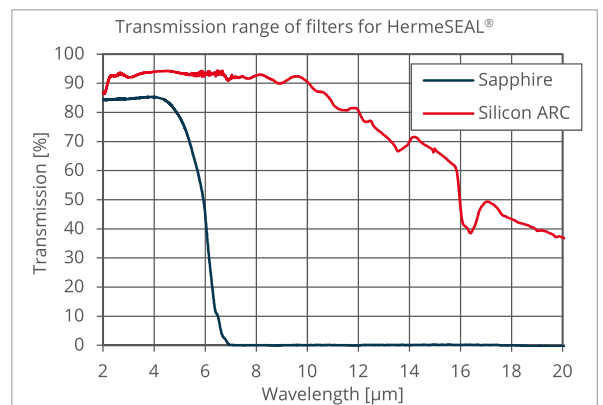
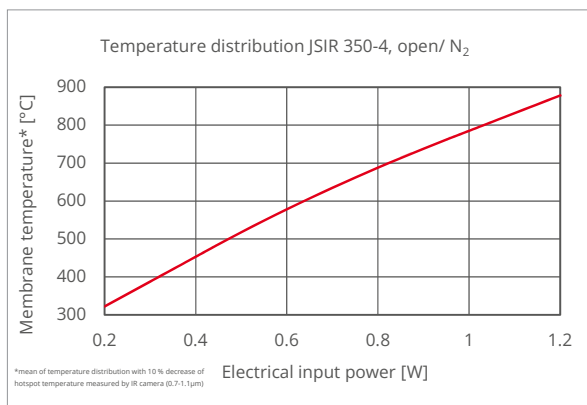
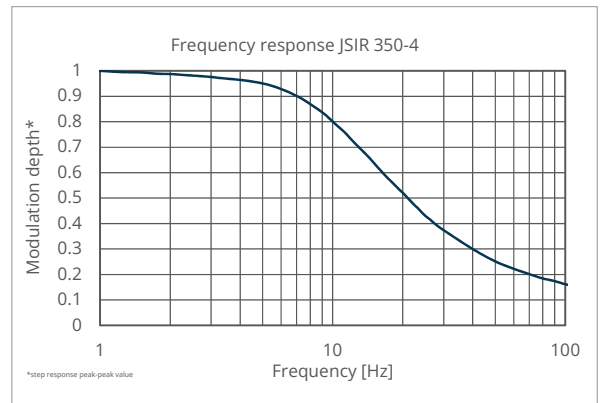
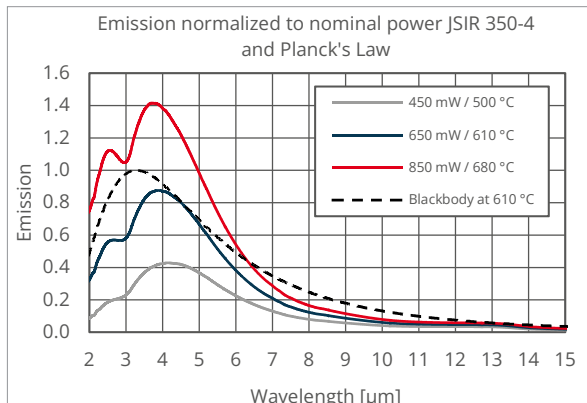

Electrical schemata

Pin out (bottom view)

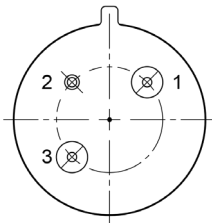

- Pin 1 – Power 1
- Pin 2 – Case
- Pin 3 – Power 2

Circuits

Equivalent circuit diagram

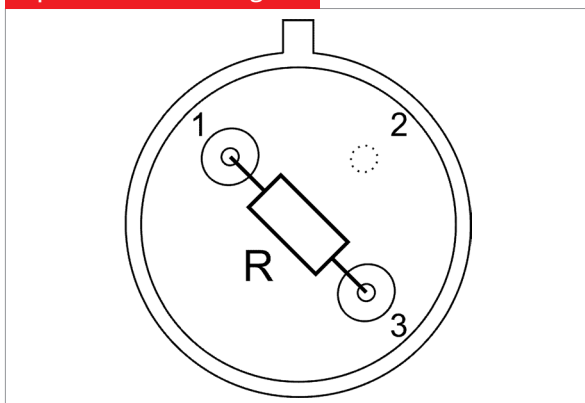

Mechanical drawings

Bottom

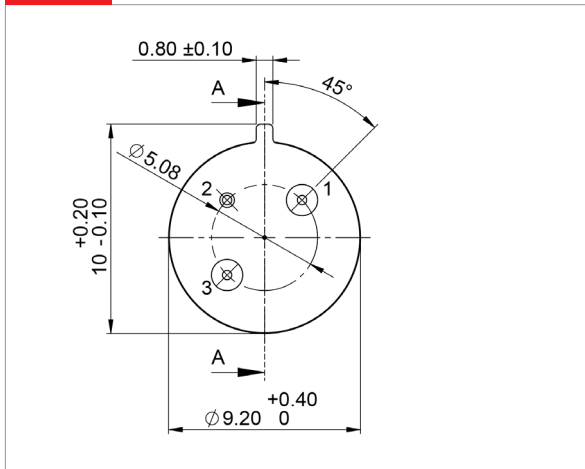

➔ All geometrical dimensions in mm

Sectional – JSIR 350 reflector, soldered filter

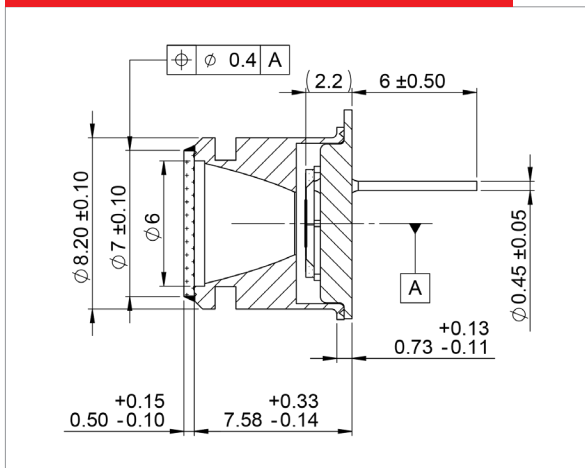

Sectional – JSIR 350 cap, soldered filter

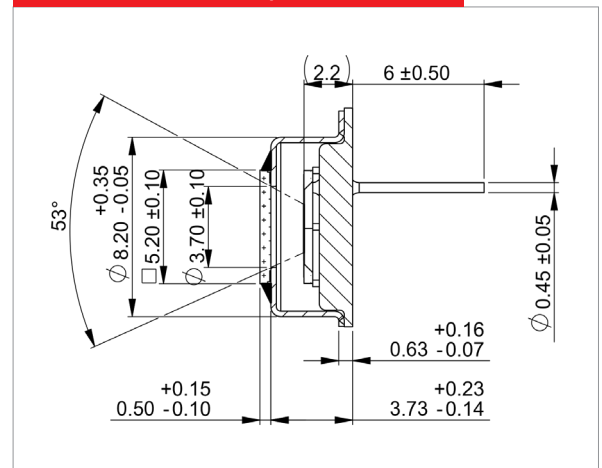

Sectional – JSIR 350 cap, soldered filter, add-on reflector

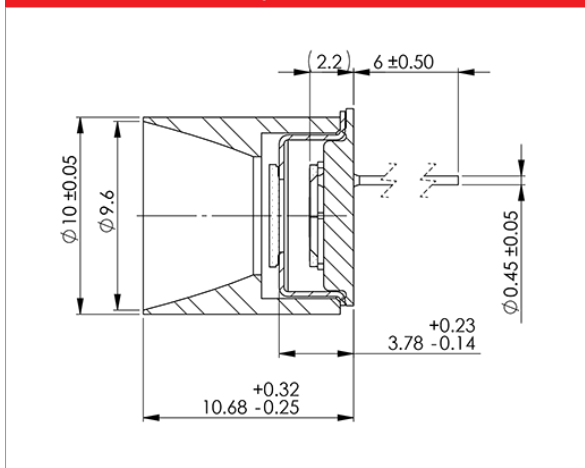

Product overview

Article	Type	Filling gas	Temp. min	Temp. max	Aperture	Window
<u>JSIR350-4-AL-C-D3.7-N2-A7-I</u>	TO39 with cap	N ₂	-20 °C	125 °C	3.7mm	Si ARC
<u>JSIR350-4-AL-C-D3.7-N2-A7-I-AO</u>	TO39 with cap, add-on reflector	N ₂	-20 °C	125 °C	3.7mm	Si ARC
<u>JSIR350-4-AL-R-D6.0-N2-A1-I</u>	TO39 with reflector	N ₂	-20 °C	185 °C	6.0 mm	Sapphire
<u>JSIR350-4-AL-R-D6.0-N2-A7-I</u>	TO39 with reflector	N ₂	-20 °C	125 °C	6.0 mm	Si ARC

Disclaimer

All rights reserved. All information in this data sheet are based on latest knowledge, results of practical experience and tests carried out. Earlier specifications are hereby invalid. All specifications – technical included – are subject to change without notice. It is the customer's responsibility to ensure that the performance of the product is suitable for customer's specific application. No liability is accepted for indirect damage, in particular for the use or inability to use the product. Any liability we may have is limited to the value of the product itself.