

JSIR 350-4

By combining standard silicon material technology with NAC coatings, Micro-Hybrid offers MEMS products with exceptional performance.



Applications

- NDIR gas analysis
- DIR spectroscopy
- ATR spectroscopy
- PAS spectroscopy

Target gases

- CO₂, CO, N₂O, NH₃, SO₂, SF₆ and ripening gases such as C₂H₄ (ethylene) and C₂H₂ (acetylene)

Features

- Broad emissivity 2 - 15 μm
- High membrane temperature up to 850 °C
- High radiation output
- High modulation frequency
- Long lifetime (reliability due to high stability of the membrane)
- HermeSEAL® technology available - see special datasheet

Additional product information

The powerful IR emitters made by our MEMS fab NOVA IR consist of nanoamorphous carbon (NAC). They reach membrane temperatures of up to 850 °C for a high and long-term stable radiation performance. JSIR 350-4 sources are available in different packaging options with cap and reflector. The spectral behavior can be individually adapted by various windows. Technical parameters such as time constant and power consumption can be adjusted with different filling gases.

Only at Micro-Hybrid: HermeSEAL® technology - a unique process that creates hermetically sealed emitters for use in harsh environments.

Online shop for IR components and sensors

Filter products simply by selecting the desired properties and request your quotation.

 microhybrid.com/shop



Technical data

Technical parameter	Open / window N ₂	Unit
Spectral output range	2 ... 15	μm
Active area	2.2 x 2.2	mm ²
Hot resistant ¹	40 ± 20	Ω
Temperature coefficient ²	typ. 500	ppm/K
Time constant _{0-63 %}	typ. 12.5	ms
Nominal power consumption ³	650	mW
Operation voltage ⁴	typ. 4.9	V
Operation current ⁴	typ. 132	mA
Recommended driving mode	Power mode	
Active area temperature ^{1,5,6}	610 ± 30	°C
Window	Available: Sapphire, BaF ₂ , CaF ₂ , Si ARC, other on request	
Housing	TO39	
Estimated lifetime ^{7,8}	> 5000 h at 740 °C > 100000 h at 610 °C	
Absolute max. ratings		
Input power ^{3,5}	1200	mW
Housing temperature ⁸	185 without window, 85 with window	°C
Active area temperature	850	°C

¹ At nominal power

² 25 °C - 800 °C

³ At power on-state

⁴ With 40 Ω hot resistant

⁵ At T_{amb} = 25 °C

⁶ Mean of temperature distribution with 10 % decrease of hotspot temperature measured by IR camera (0.7-1.1μm)

⁷ Continuous mode, MTF 63 % (membrane fracture, calculated values based on Arrhenius)

⁸ Including ambient temperature

Typical operating characteristics

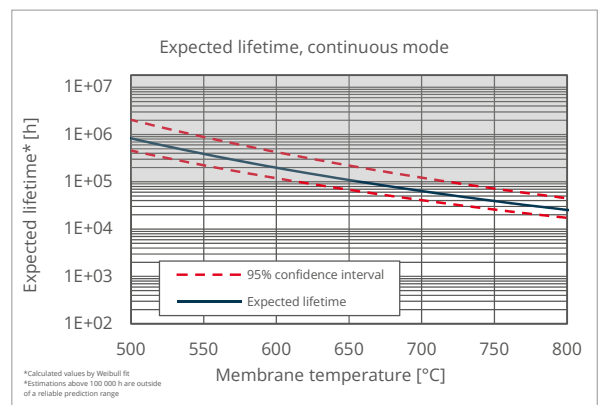
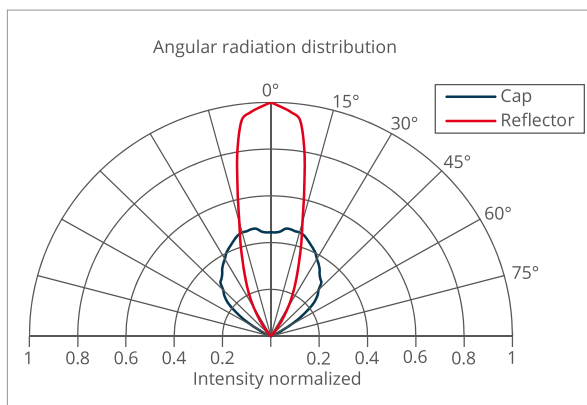
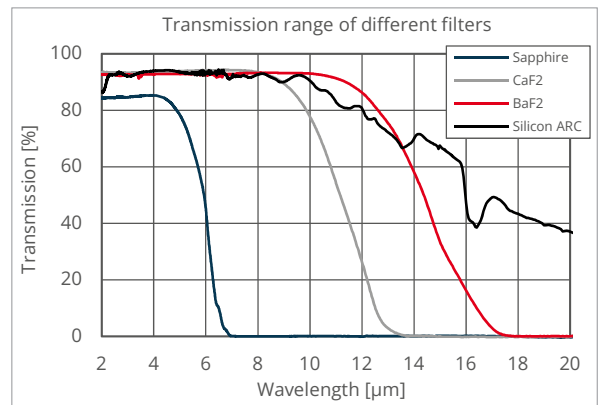
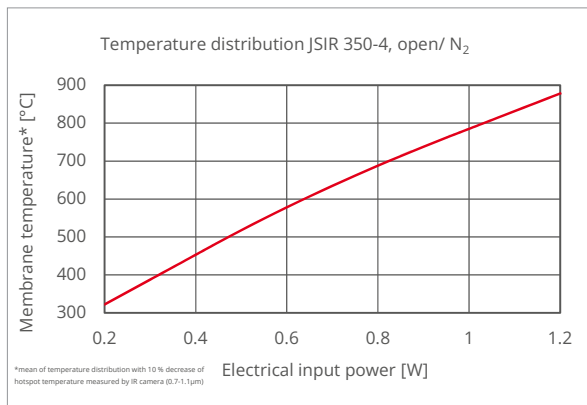
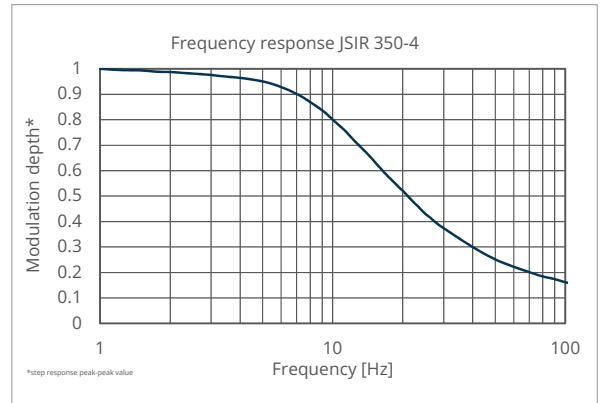
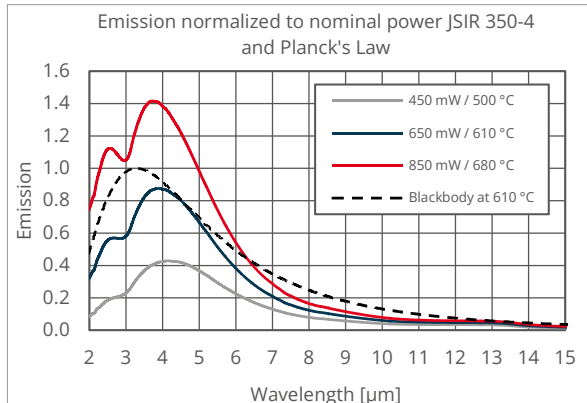

Electrical schemata

Pin out (bottom view)

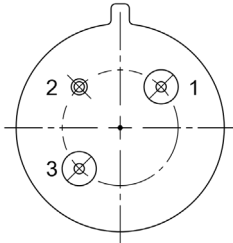

- Pin 1 – Power 1
- Pin 2 – Case
- Pin 3 – Power 2

Circuits

Equivalent circuit diagram

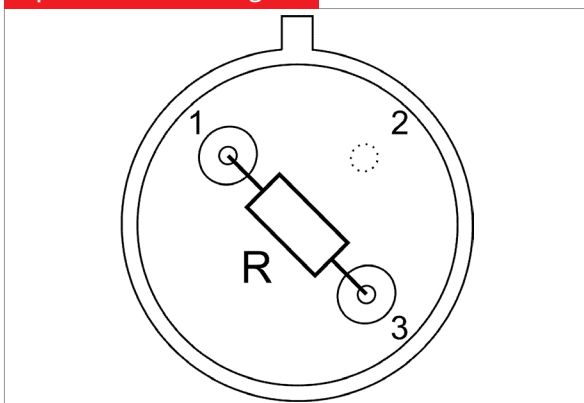

Mechanical drawings

Bottom

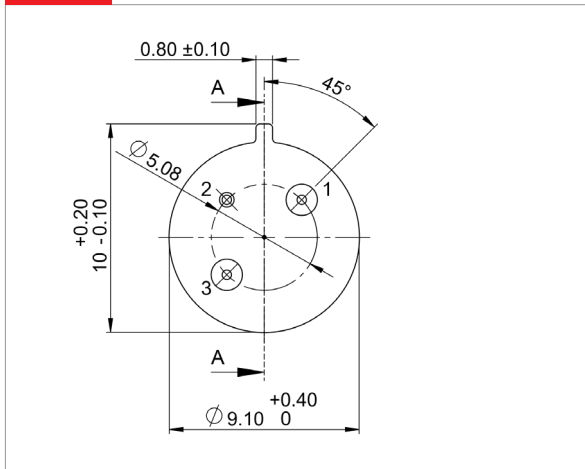

➔ All geometrical dimensions in mm

Sectional – JSIR 350-4 cap open

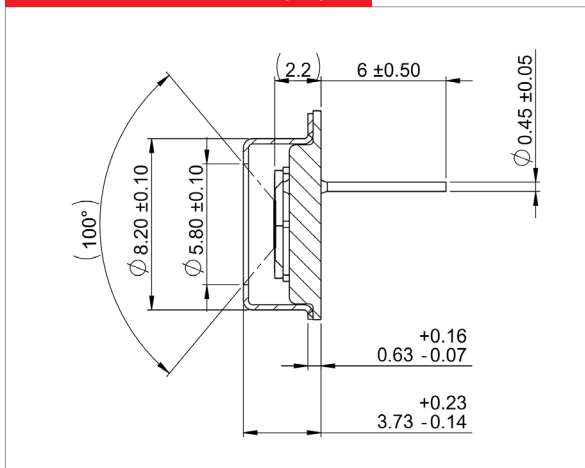

Sectional – JSIR 350-4 cap with filter

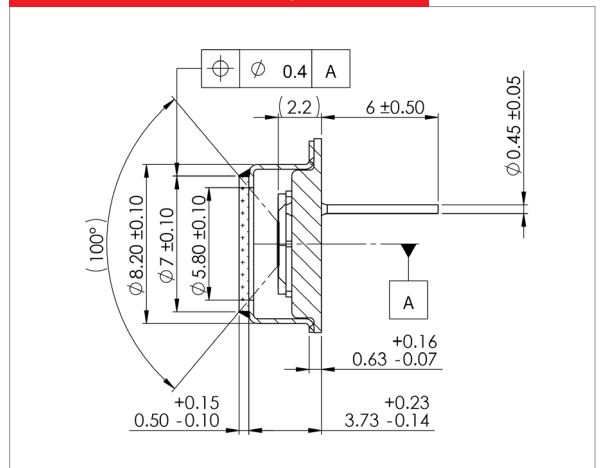

Sectional – JSIR 350-4 reflector open

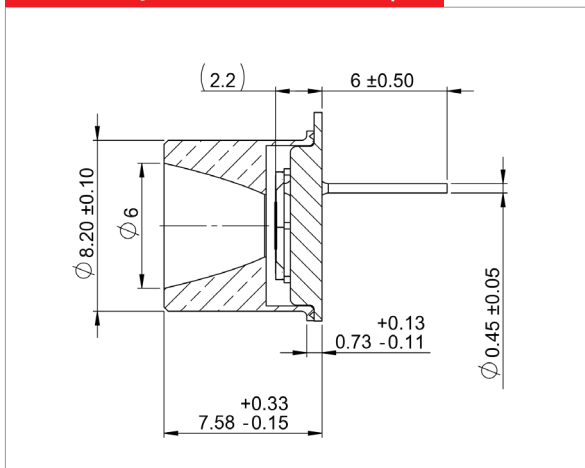

Sectional – JSIR 350-4 reflector with filter

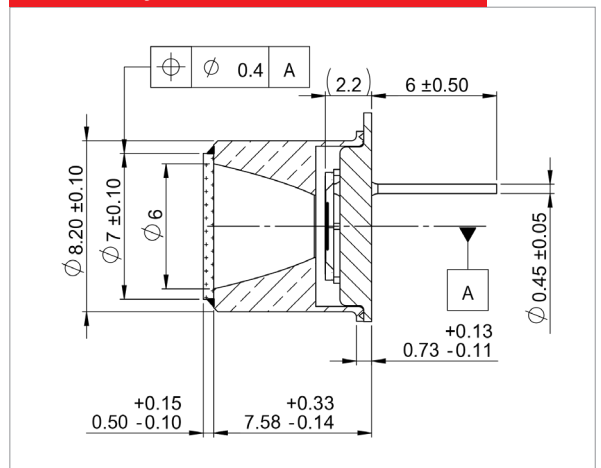

Product overview

Article	Type	Filling gas	Temp. min	Temp. max	Aperture	Window
JSIR350-4-AL-C-D5.8-0-0	TO39 with cap	None	-20 °C	185 °C	5.8 mm	Open
JSIR350-4-AL-C-D5.8-N2-A1	TO39 with cap	N ₂	-20 °C	85 °C	5.8 mm	Sapphire
JSIR350-4-AL-C-D5.8-N2-A2	TO39 with cap	N ₂	-20 °C	85 °C	5.8 mm	CaF ₂
JSIR350-4-AL-C-D5.8-N2-A4	TO39 with cap	N ₂	-20 °C	85 °C	5.8 mm	BaF ₂
JSIR350-4-AL-R-D6.0-0-0	TO39 with reflector	None	-20 °C	185 °C	6.0 mm	Open
JSIR350-4-AL-R-D6.0-N2-A1	TO39 with reflector	N ₂	-20 °C	85 °C	6.0 mm	Sapphire
JSIR350-4-AL-R-D6.0-N2-A2	TO39 with reflector	N ₂	-20 °C	85 °C	6.0 mm	CaF ₂
JSIR350-4-AL-R-D6.0-N2-A4	TO39 with reflector	N ₂	-20 °C	85 °C	6.0 mm	BaF ₂

Disclaimer

All rights reserved. All information in this data sheet are based on latest knowledge, results of practical experience and tests carried out. Earlier specifications are hereby invalid. All specifications – technical included – are subject to change without notice. It is the customer's responsibility to ensure that the performance of the product is suitable for customer's specific application. No liability is accepted for indirect damage, in particular for the use or inability to use the product. Any liability we may have is limited to the value of the product itself.