



MICRO-HYBRID



Operating Instructions

inertial**SENSOR ACC5703**

ACC5703

3-axes acceleration sensor

Micro-Hybrid Electronic GmbH
Heinrich-Hertz-Straße 8
07629 Hermsdorf / Germany

Tel. +49 36601 592100
contact@microhybrid.com
www.microhybrid.com

Contents

1.	Safety	5
1.1	Symbols Used	5
1.2	Warnings	5
1.3	Notes on CE Marking	6
1.4	Intended Use	6
1.5	Proper Environment.....	7
2.	Functional Principle, Technical Data	8
2.1	Functional Principle	8
2.2	Structure and Electrical Connection.....	8
2.3	Technical Data	9
3.	Delivery	11
3.1	Unpacking, Included in Delivery.....	11
3.2	Storage	11
4.	Installation and Assembly	12
4.1	Sensor Cable	12
4.2	Sensor.....	12
4.3	Pin Assignment.....	14
4.4	Analog Output.....	15
	4.4.1 Continuous Operation Mode.....	16
	4.4.2 Switching Operation Mode.....	17
4.5	Configuration of Sampling Rate and Low- and High-pass Filter	19
4.6	Digital Output RS485	20
5.	Operation	21
6.	Liability for Material Defects	22
7.	Service, Repair	22
8.	Decommissioning, Disposal	22

Appendix

A 1	Optional Accessories	23
A 2	Factory Settings	23
A 3	Software	24
A 3.1	Sensor Finder	24
A 3.2	Measurement Menu	27
	A 3.2.1 Main View	28
	A 3.2.2 Start/Stop	28
	A 3.2.3 Signal Processing	29
	A 3.2.4 CSV Output	30
A 3.3	Frequency Analysis (FFT) Menu	32
A 3.4	Single Value Menu	33
A 3.5	Settings Menu	35
	A 3.5.1 Filter Configuration	36
	A 3.5.2 Measuring Range	37
	A 3.5.3 Output 1, 2, 3	38
A 3.6	Info Menu	39
A 4	Digital Interface RS485	41
A 4.1	Hardware Interface	41
A 4.2	Protocol	41
	A 4.2.1 Reading Measurement Data	41
	A 4.2.2 Example Transmission of a Measurement Value	46

1. Safety

System operation assumes knowledge of the operating instructions.

1.1 Symbols Used

The following symbols are used in these operating instructions:



Indicates a hazardous situation which, if not avoided, may result in minor or moderate injury.



Indicates a situation that may result in property damage if not avoided.



Indicates a user action.



Indicates a tip for users.

1.2 Warnings



Connect the power supply and the display/output device according to the safety regulations for electrical equipment.

> Risk of injury

> Damage to or destruction of the sensor



The supply voltage must not exceed the specified limits.

> Damage to or destruction of the sensor

No sharp or heavy objects should be allowed to affect the cables. Avoid folding the cables. Do not bend more tightly than the minimum bending radius of the cables.

> Damage or destruction of the cable, failure of the measuring device

Do not crush the cable. Protect the sensor cable against damage.

> Damage or destruction of the cable, failure of the measuring device, data loss

Ensure that the coupling nuts of the connectors are firmly tightened.

> Damage or destruction of the cable, failure of the measuring device

1.3 Notes on CE Marking

The following apply to the ACC5703:

- EU Directive 2014/30/EU
- EU Directive 2011/65/EU

Products which carry the CE mark satisfy the requirements of the EU directives cited and the European harmonized standards (EN) listed therein. The EU Declaration of Conformity is available to the responsible authorities according to EU Directive, article 10, at:

Micro-Hybrid Electronic GmbH

Heinrich-Hertz-Straße 8
07629 Hermsdorf / Germany

The measuring system is designed for use in industrial environments and meets the requirements.

1.4 Intended Use

The ACC5703 is designed for use in industrial applications. It is used for

- measuring acceleration
- measuring vibration of manoeuvrable components
- The system must only be operated within the limits specified in the technical data, [see 2.3](#).
- The sensor must be used in such a way that no persons are endangered or machines and other material goods are damaged in the event of malfunction or total failure of the sensor.
- Take additional precautions for safety and damage prevention in case of safety-related applications.

1.5 Proper Environment

- Protection class: ¹ IP 67
- Temperature range:
 - Operation: -40 ... +85 °C (-40 ... +185 °F)
 - Storage: -40 ... +85 °C (-40 ... +185 °F)
- Ambient pressure: Atmospheric pressure

1) With M12 connector

2. Functional Principle, Technical Data

2.1 Functional Principle

With the principle of an acceleration sensor, forces that change the velocity of an object are measured and transformed into an electric output signal.

Therefore the sensor is mounted on the maneuverable component. The expected moves correspond to the measurement axes. The included MEMS-Element converts the acceleration into a usable electric signal.

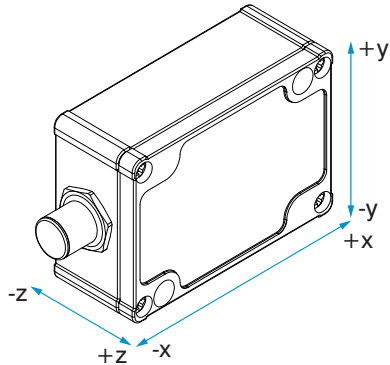

Fig. 1 Three axes acceleration sensor

2.2 Structure and Electrical Connection

The sensor is ready for operation immediately after connecting the power supply and will provide the acceleration as electric value at the analog output.

The ACC5703 is available with analog (current, voltage and switching output) as well as RS485 interface for configuring of the sensor using the software.

Power supply and signal output are connected through a 8-contact (M12) connector on the sensor's housing.

2.3 Technical Data

Model		ACC5703-8
Number of axes		3
Measuring range		$\pm 0.1 \text{ g} \dots \pm 8 \text{ g}$ (configurable) ¹
Resolution	Digital	$\leq 0.016 \text{ mg}$
	Analog	Current: $\leq 0.24 \text{ mg} / \text{voltage} \leq 0.31 \text{ mg}$
Noise		Typ. $30 \mu\text{g} / \sqrt{\text{Hz}}$
Sensitivity (analog output)		$\leq 80 \text{ mA/g}$ or $\leq 20 \text{ V/g}$ ¹
Zero		12 mA or 2.5 V
Linearity		Typ. 0.45 % FSO
Frequency range		0 ... 1000 Hz (configurable)
Sampling rate		Up to 4 kHz ²
Cross axis sensitivity		1 % FSO
Temperature stability		Typ. $\pm 0.2 \text{ mg} / \text{K}$
Supply voltage		5 ... 32 VDC
Power consumption		< 3 W
Temperature range	Operation	$-40 \dots +85 \text{ }^\circ\text{C}$ ($-40 \dots +185 \text{ }^\circ\text{F}$) ³
	Storage	$-40 \dots +85 \text{ }^\circ\text{C}$ ($-40 \dots +185 \text{ }^\circ\text{F}$)
Digital interface		RS485 ⁴
Analog output		4 ... 20 mA (max. 390 Ω) and 0.5 ... 4.5 V (min. 1 k Ω) (configurable)
Switching output		0 / 5 V (min. 1 k Ω)
Protection class		IP 67 (connected)

Model	ACC5703-8
Shock	DIN EN 60068-2-27 (1500 g, 0.5 ms, half-sine shock, 3 x in each direction)
Weight	Approx. 250 g
Material	Die-cast aluminum
Installation	Screw connection via mounting holes (M4)
Connection	M12 connector, 8-pin
Start-up time	< 500 ms

FSO = Full Scale Output

All specifications valid at a room temperature of +25 °C (+77 °F)

- 1) In order to achieve maximum sensitivity, continuous adjustment of the measuring range is possible.
(Examples: Measuring range ± 0.1 g \rightarrow Sensitivity 80 mA/g or 20 V/g; Measuring range ± 8 g \rightarrow Sensitivity 1 mA/g or 0.25 V/g)
- 2) The digital interface RS485 is active only up to a sampling rate of 1000 Hz. At higher rates only the analog output is active.
- 3) Customer-specific designs up to +125 °C
- 4) Compatible with the MICRO-Epsilon interface modules IF1032 (Ethernet) and IF2030 (PROFINET)

Article designation

ACC	5703	-8	-SA	-U/I
				Output U/I = 0.5 ... 4.5 V, 4 ... 20 mA, 0 / 5 V, RS485
				Connection: SA = axial plug
				Measuring range in \pm g
				High-precision acceleration sensor

3. Delivery

3.1 Unpacking, Included in Delivery

1 Sensor ACC5703

1 Operating Instructions

➡ Carefully remove the components of the measuring system from the packaging and ensure that the goods are forwarded in such a way that no damage can occur.

➡ Check the delivery for completeness and shipping damage immediately after unpacking.

➡ If there is damage or parts are missing, immediately contact the manufacturer or supplier.

Optional accessories are available in the appendix, [see A 1](#).

3.2 Storage

Temperature range storage: -40 ... +85 °C (-40 ... +185 °F)

Humidity: 5 - 95 % (non-condensing)

4. Installation and Assembly

4.1 Sensor Cable

NOTICE

No sharp or heavy objects should be allowed to affect the cables. Avoid folding the cables. Do not bend more tightly than the minimum bending radius of the cables.

> Damage or destruction of the cable, failure of the measuring device

Do not crush the cable. Protect the sensor cable against damage.

> Damage or destruction of the cable, failure of the measuring device

Ensure that the coupling nuts of the connectors are firmly tightened.

> Damage or destruction of the cable, failure of the measuring device

4.2 Sensor

The sensor is fixed into place with the help of two through bores for M4 screws.

The sensor is mounted at the manoeuvrable component. The orientation of the measurement axes x, y, z is to be respected in relation to the expected moves of the component.

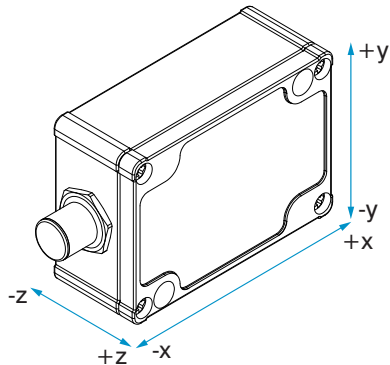

Fig. 2 Installation orientation, measurement axis

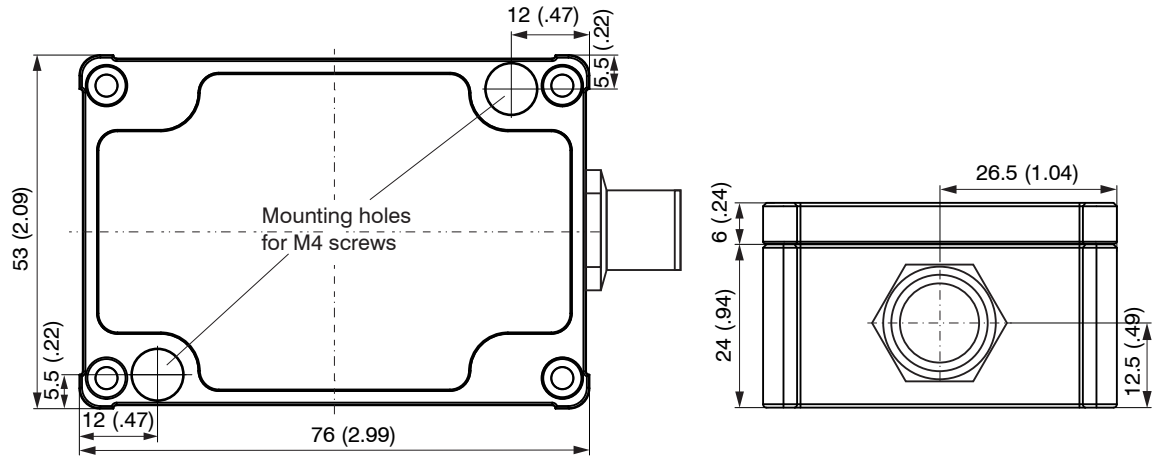

Fig. 3 Dimensional drawing, dimensions in mm (inches), not to scale

4.3 Pin Assignment



Pin	Color ¹	Description	
1	White	Output channel 2	
2	Brown	GND (Output)	
3	Green	Output channel 3	
4	Yellow	RS485+	
5	Gray	Output channel 1	
6	Black/pink	GND (Supply)	
7	Blue	RS485-	
8	Red	Supply +	
			Front view of sensor's 8-pin, A-coded, male connector

Fig. 4 Pin assignment of the 8-pin, A-coded, female connector

1) - Colors of particular wires may differ, depending on selection of connection cable

4.4 Analog Output

The sensor makes the acceleration value available as analog output variable either as current or voltage value on separate pins.

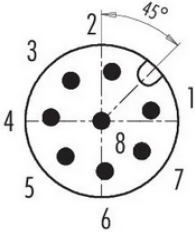
Three output channels can be configured independently with the following settings.

- Analog channel 1 (x, y, z)
- Analog channel 2 (x, y, z)
- Analog channel 3 (x, y, z)

Each output channel can be operated in continuous operation mode or switching operation mode.

Selection of measurement axis (x, y, z) at every channel possible
Off (zero output)
Continuous mode, current 4 - 20 mA
Continuous mode, voltage 0.5 - 4.5 V
Switching mode, voltage 0 - 5 V

Fig. 5 Operation modes of the analog output channels

You can switch between the continuous operation mode and the switching operation mode, [see A 3.5.3](#).

4.4.1 Continuous Operation Mode

The sensor makes the acceleration value available as analog output variable either as current or voltage value on separate pins, depending on the configuration using the sensorTOOL software of Micro-Epsilon.

In this process, the symmetrical measurement range in the unit g is scaled to the respective analog range.

The sensitivity increases with decreasing measurement range as only a small acceleration range is scaled to the same output range, see Fig. 6, see Fig. 7.

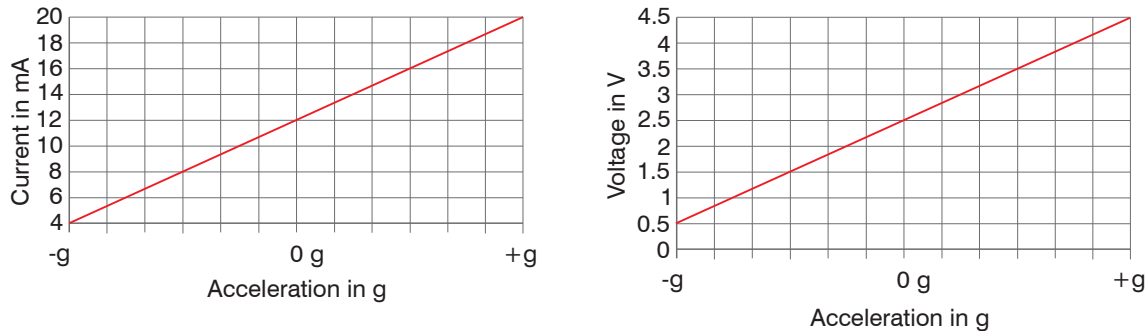

Fig. 6 Scaling of the acceleration measurement range to analog output variable current or voltage

Measuring range [g]	Resolution digital RS485 [mg]	Resolution analog current [mg]	Resolution analog voltage [mg]	Sensitivity analog current [mA/g]	Sensitivity analog voltage s[V/g]
≤ ±2	0.004	0.06	0.076	≥ 4.0	≥ 1.0
≤ ±4	0.008	0.12	0.15	≥ 2.0	≥ 0.5
≤ ±8	0.016	0.24	0.31	≥ 1.0	≥ 0.25

Fig. 7 Examples of resolution (mg) and sensitivity (mA/g) depending on the configured measurement range

4.4.2 Switching Operation Mode

The switching mode, configurable via Software, switches the analog voltage output to 5 V when the acceleration value reaches the trigger-level “on-level” and switches back to 0 V when the acceleration value falls below the “off-level”.

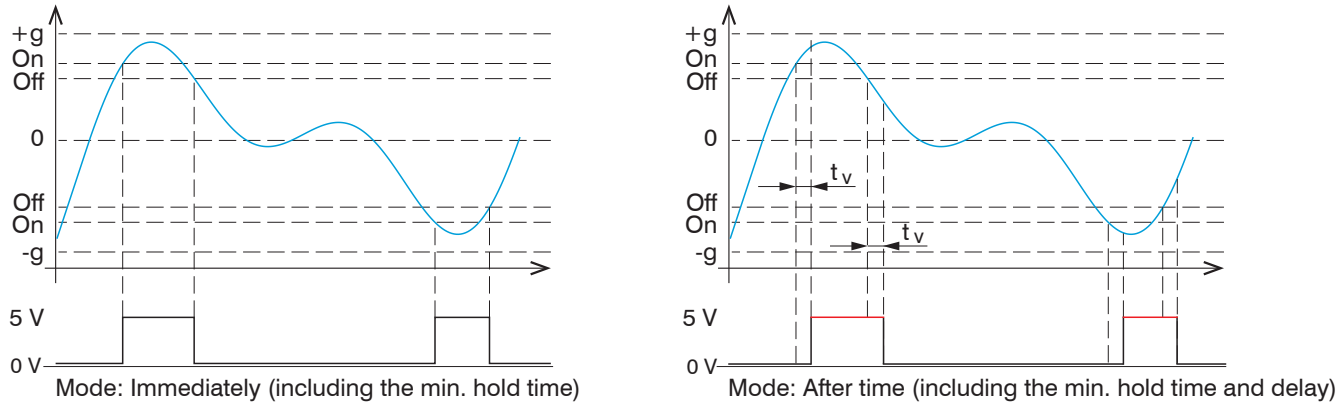

Fig. 8 Switching operation mode, response time <math>< 10 \mu\text{s}</math>, see Fig. 9

The selection of measurement axis (x, y, z) (vector addition (xy, xz, yz, xyz)) is possible at every channel.

Mode Immediately:

➤ Select this setting to switch the output immediately when the switching levels are exceeded or not reached, see Fig. 8 (left).

The switching status has a minimum hold time. The minimum hold time of the switching status depends on the sampling rate set, see Fig. 10.

Mode After Time:

➤ Choose the delay time t_v for which the switching level must be permanently exceeded or not reached in order to switch the output, see Fig. 8 (right).

The delay time t_v determines the switch-on delay and the switch-off delay of the switching status to the same degree, see Fig. 8 (right). The switching status has a minimum hold time. The minimum hold time of the switching status depends on the sampling rate set, see Fig. 10.

That functionality can be used, for example, as safety feature which switches off a machine if high vibrations occur. The trigger-levels take effect symmetrically, i.e. in the positive and negative acceleration range at the same absolute value.

The output values at the digital interface in switching mode are either zero or equal to the “on-level” as long as the trigger condition is met.

The duration of the rising and falling edge is $t < 10 \mu\text{s}$, see Fig. 9.

The minimum hold time of the switching status depends on the selected sampling rate, see Fig. 10.

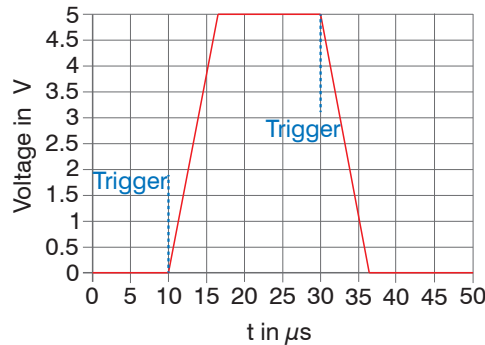

Fig. 9 Rising and falling edge of the voltage output in switching mode, $t < 10 \mu\text{s}$

Sampling rate (Hz)	Minimum hold time of switching status (ms)
4000	25
2000	25
1000	25
500	26
250	28
125	32
62.5	32
31.25	32
15.625	64
7.8125	128
3.90625	256

Fig. 10 Minimum hold time of the switching status

4.5 Configuration of Sampling Rate and Low- and High-pass Filter

Parameters, like sampling rate or filter frequencies, are adaptable in a wide range in order to match the respective application.

The high-pass is configured to reduce influences of low frequencies especially to hide earth acceleration. The low-pass is configured to hide disturbances at high frequency.

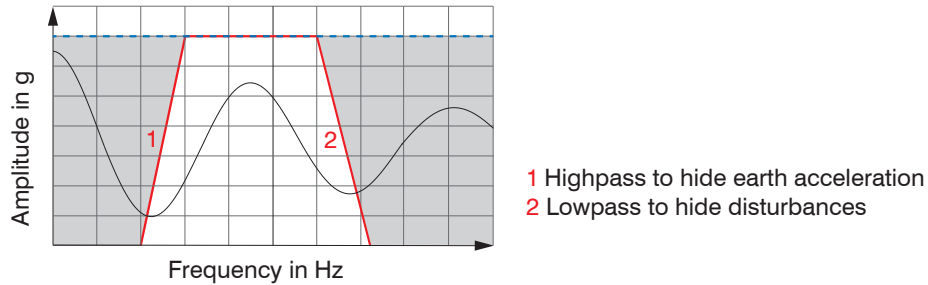

Fig. 11 Configuration of filter to reduce influences

The high-pass is deactivated by default, [see A 2..](#)

Different low-pass filter settings, see Fig. 12, cause the sampling rate and response time to change respectively. The chosen low-pass frequencies furthermore have influence on the available high-pass filter options.

Low-pass f_{LP} [Hz] (configurable)	Sampling rate [Hz]	Response time [ms]	High-pass f_{HP} [Hz] (optional, configurable)
1000	4000 ¹	0.88	0.00952 ... 9.88
500	2000 ¹	1.25	0.00476 ... 4.94
250	1000	2.03	0.00238 ... 2.47
125	500	3.51	0.00119 ... 1.235
62.5	250	6.52	0.000595 ... 0.6175
31.25	125	12.59	0.0002975 ... 0.30875
15.625	62.5	24.43	0.00014875 ... 0.154375
7.813	31.25	47.84	7.4375e-5 ... 0.0771875
3.906	15.625	96.5	3.71875e-5 ... 0.03859
1.953	7.813	189.83	1.859e-5 ... 0.0193
0.977	3.906	384.56	9.296e-6 ... 0.009648

Fig. 12 Table dependency between sampling rate and low- and high-pass settings

- 1) Digital interface RS485 is enabled only up to 1000 Hz sampling rate. At higher rates only the analog output is active.

4.6 Digital Output RS485

You can read out the measured data in digital form using the RS485 interface in a sampling rate up 1000 Hz. For higher sampling rates only the analog operation is possible. The PC software sensorTool, see A 3, permits configuration of the sensor and the visualization of the measured data. The bus protocol required to read out the measured data in your own applications is described in the appendix, see A 4.

Additionally, you can use the IF1032/ETH interface converter by MICRO-EPSILON MESSTECHNIK GmbH & Co. KG, to read out the measured data via Ethernet.

5. Operation

The measurement device is already calibrated when delivered. Calibration by the user is not necessary. After connection to the operating voltage, the sensor is immediately ready for operation and independently initiates the measurement, see Fig. 13.

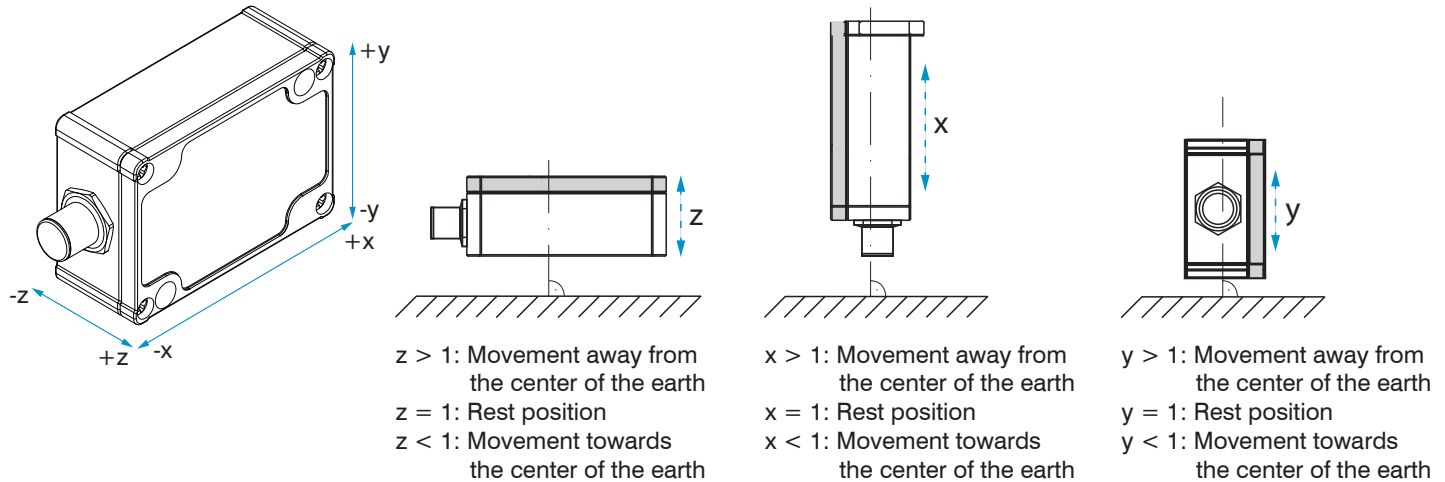

Fig. 13 Reference directions for the acceleration measurement based on the example of the acceleration of gravity

Additionally, the digital RS485 interface is ready to react to enquiries by the master (periodic retrieval of measured data).

For sensor configuration please use the power supply and output cable with USB/RS485 converter, see A 1, as well as the sensor-TOOL software of MICRO-EPSILON, see A 3.



The sensor requires a warm-up time of approx. 10 minutes after connection of the voltage supply.

6. Liability for Material Defects

All components of the device have been checked and tested for functionality at the factory. However, if defects occur despite our careful quality control, Micro-Hybrid or your dealer must be notified immediately. The liability for material defects is 12 months from delivery.

Within this period, defective parts, except for wearing parts, will be repaired or replaced free of charge, if the device is returned to Micro-Hybrid with shipping costs prepaid. Any damage that is caused by improper handling, the use of force or by repairs or modifications by third parties is not covered by the liability for material defects. Repairs are carried out exclusively by Micro-Hybrid.

Further claims can not be made. Claims arising from the purchase contract remain unaffected. In particular, Micro-Hybrid shall not be liable for any consequential, special, indirect or incidental damage. In the interest of further development, Micro-Hybrid reserves the right to make design changes without notification.

7. Service, Repair

If the sensor is defective, please send us the affected parts for repair or exchange.

If the cause of a fault cannot be clearly identified, please send the entire measuring system to:

Micro-Hybrid Electronic GmbH
Heinrich-Hertz-Straße 8

07629 Hermsdorf / Germany

Tel. +49 36601 592100
contact@microhybrid.com
www.microhybrid.com

8. Decommissioning, Disposal

➡ Remove the power and output cable from the sensor.

Incorrect disposal may cause harm to the environment.

➡ Dispose of the device, its components and accessories, as well as the packaging materials in compliance with the applicable country-specific waste treatment and disposal regulations of the region of use.

Appendix

A 1 Optional Accessories

Designation	Description
VKM055419	PC1/8 Parametrization kit incl. Power supply for digital inertial sensors M12, 8 pin
VKM055421	PC3/8 M12 8-wire, supply and signal cable, 3 m

A 2 Factory Settings

Low-pass filter: 62,5 Hz

Sampling rate: 250 Hz

High-pass filter: Disabled

Measurement range: ± 2 g

Sensitivity: 4 mA/g or 1 V/g

Output signal: 4 ... 20 mA

Active axes: Channel 1: "x", channel 2: "y", channel 3: "z", [see Fig. 2](#)

A 3 Software

The sensorTOOL offers you a documented driver software. It is available at www.micro-epsilon.com.

A 3.1 Sensor Finder

- ➡ Connect the sensor to a free USB port on your PCs and connect the power supply.
- ➡ Activate the sensorTOOL.

The following view appears:

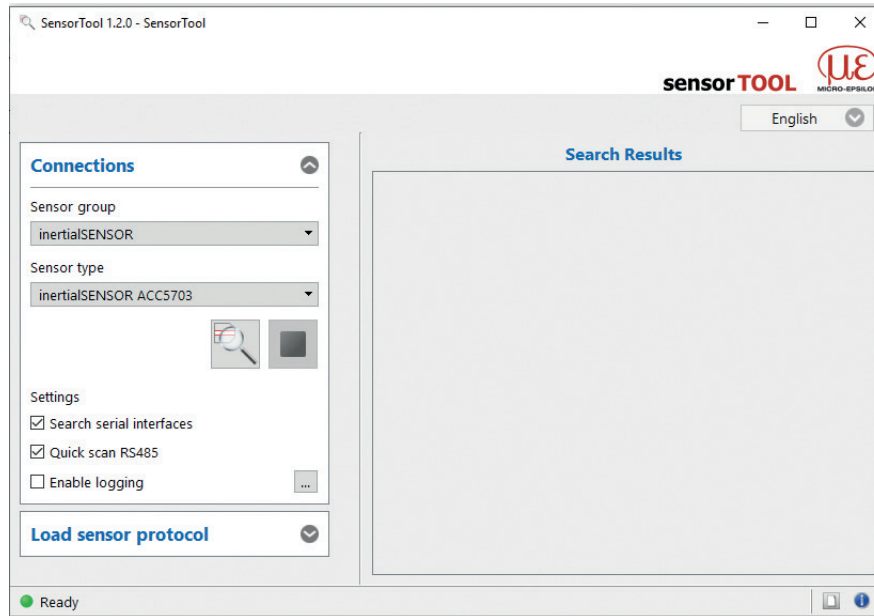

Fig. 14 First interactive site after calling the sensorTOOL

➡ In the drop down menus, set the sensor group inertialSENSOR and the corresponding sensor type and activate the other settings, see Fig. 14.

➡ Now click the Search  button.

Now the Search Results (x) view displays the number of sensors found, see Fig. 15.

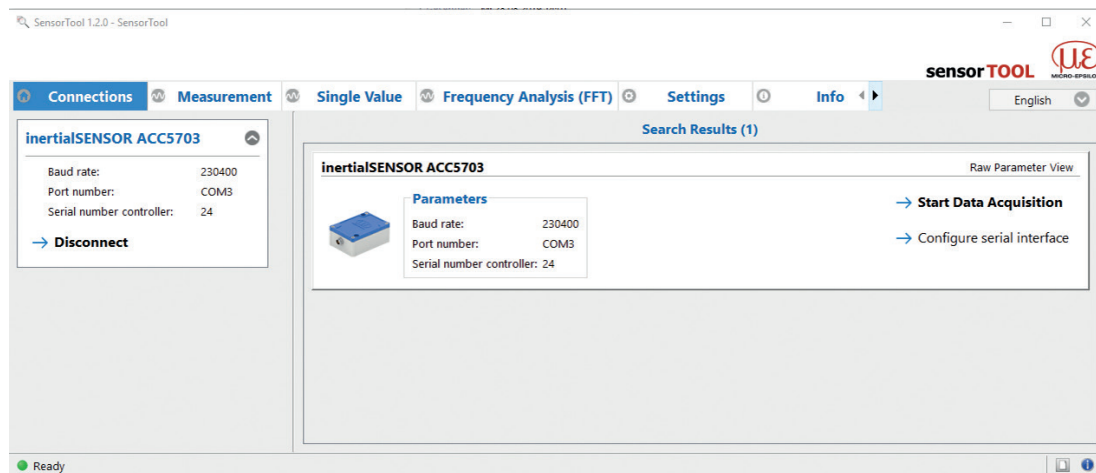

Fig. 15 Main view

➡ Click the Configure Serial Interface button to set the basic settings for the serial interface.

Change serial configuration - SensorTool

Serial configuration

Controller name: ACC5703
Sensor name: inertialSENSOR ACC5703
Serial number (controller): 24
COM-Port: COM3
Baud rate: 230400
Sensor address: 125

New serial configuration

Baud rate: 230400
Sensor address: 125

Update serial configuration:

Fig. 16 Window Change Serial Configuration - sensorTOOL

The baud rate cannot be changed.

A sensor address can be assigned for the sensor.

➡ Start the data acquisition/configuration by clicking `Start Data Acquisition` or the sensor picture, see Fig. 15.

The following window appears, see Fig. 17.

A 3.2 Measurement Menu

To check your measurements, a simple data acquisition, [see Fig. 17](#), is available.

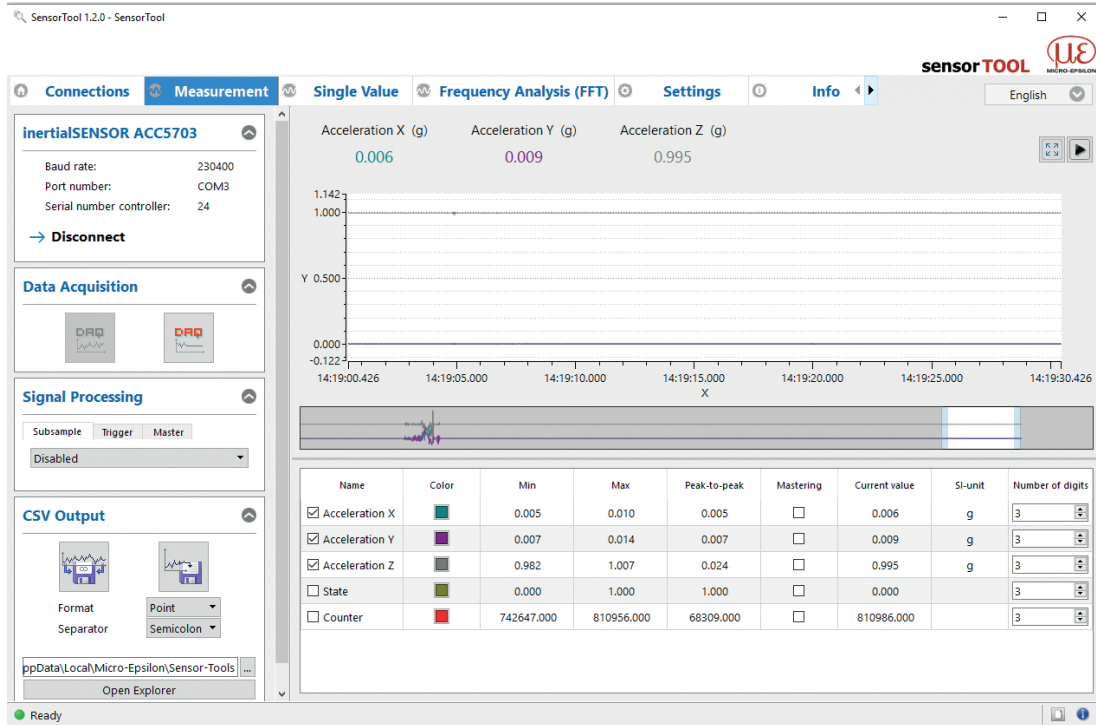

Fig. 17 View data acquisition menu

A 3.2.1 Main View

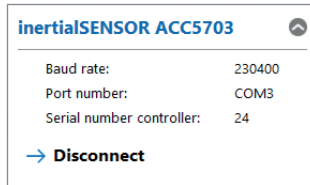

Fig. 18 Disconnection

By clicking the `Disconnect` button you return to the sensor search, see Fig. 14.



Click the `Reset Y-Scale` button, to reset the Y-scale to initial settings (e.g. after zooming).



Click the `Jump to Head` button to display the current signal course.

A 3.2.2 Start/Stop



Start the data acquisition by clicking the `Start` button, see Fig. 19.

The acquisition is completely restarted and the record stopped before is deleted.



Stop the data acquisition by clicking the `Stop` button, see Fig. 20.



Fig. 19 Start Fig. 20 Stop

A 3.2.3 Signal Processing

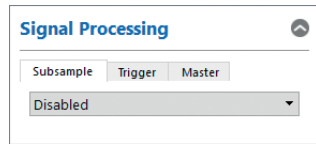

Fig. 21 Signal processing

You can select the following options for signal processing:

Measurement	Signal processing	Subsample	Disabled	Deactivated; basic settings
			Sample-based	Number of samples is adjustable, every x th measurement is recorded.
			Time-based	Time can be set in milliseconds ¹ .
		Trigger	Disabled	Deactivated; basic settings
			Continuous	Manual trigger
			One-shot (sample-based)	Sample can be set; records the signal course according to the set samples; the more samples, the longer the course.
			One-shot (time-based)	Milliseconds can be set; records the signal course according to the time set.
		Master	Master now	Sets the master, see Fig. 24 .
			Reset	Resets the master.

1) For example every 5000 ms: The signal course displayed is updated after this period has elapsed.

A 3.2.4 CSV Output

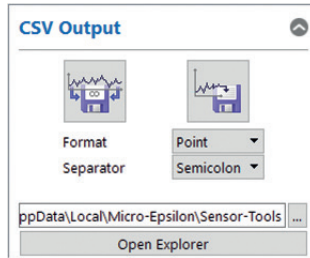

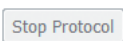

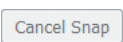



Fig. 22 CSV output

	➔ Click the button to start acquiring the measurement data.
	➔ Click the button to stop recording.
	➔ Click the button to save the selected measurement value.
	➔ Click the button to cancel the recording.

 Fields with gray backgrounds require a selection.

 Value Fields with dark border require entry of a value.

Measurement	CSV output	<i>Format</i>	<i>Point / Comma</i>
		<i>Separator</i>	<i>Comma / Semicolon / Tabulator</i>

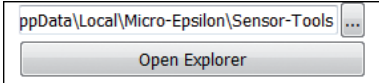







Fig. 23 Open Explorer

Name	Color	Min	Max	Peak-to-peak	Mastering	Current value	SI-unit	Number of digits
<input checked="" type="checkbox"/> Acceleration X		0.005	0.010	0.005	<input type="checkbox"/>	0.008	g	<input type="text" value="3"/>
<input checked="" type="checkbox"/> Acceleration Y		0.007	0.013	0.006	<input type="checkbox"/>	0.010	g	<input type="text" value="3"/>
<input checked="" type="checkbox"/> Acceleration Z		0.990	1.001	0.011	<input type="checkbox"/>	0.996	g	<input type="text" value="3"/>
<input type="checkbox"/> State		0.000	0.000	0.000	<input type="checkbox"/>	0.000		<input type="text" value="3"/>
<input type="checkbox"/> Counter		1423619.000	1498859.000	75240.000	<input type="checkbox"/>	1498908.000		<input type="text" value="3"/>

Name	Show or hide signal curves of the sensors used.
Color	Change the color settings of the single signal courses.
Mastering	By activating the <code>Mastering</code> checkbox you can manually enter the master value. Master now in the <code>Data Acquisition > Signal Processing</code> menu in the <code>Master</code> tab menu sets the master value, see Fig. 21 .

Fig. 24 Depiction and description of data acquisition table

A 3.3 Frequency Analysis (FFT) Menu

To analyze your measurements, a simple frequency analysis, [see Fig. 25](#), is available.

Fig. 25 Frequency Analysis

Frequency analysis (FFT)	Window size (samples)	16 / 32 / 64 / 128 / 256 / 512 / 1024 / 2048	<i>This setting specifies the window size (number of sensor values) over which the FFT is calculated. Window size high → higher frequency resolution of the FFT, but slower to calculate; Window size low → lower frequency resolution of the FFT, but faster to calculate</i>
	Maxima count	1 / 2 / 3 / 4 / 5	<i>Specifies the number of maxima that are calculated and thus can be displayed.</i>

The `Show Maxima` checkbox graphically frames the maxima. The minimum distance between the maxima [Hz] indicates the minimum distance in [Hz] which should be between two fields with gray maxima.

Fields with gray backgrounds require a selection.

Value
Fields with dark border require entry of a value.

A 3.4 Single Value Menu

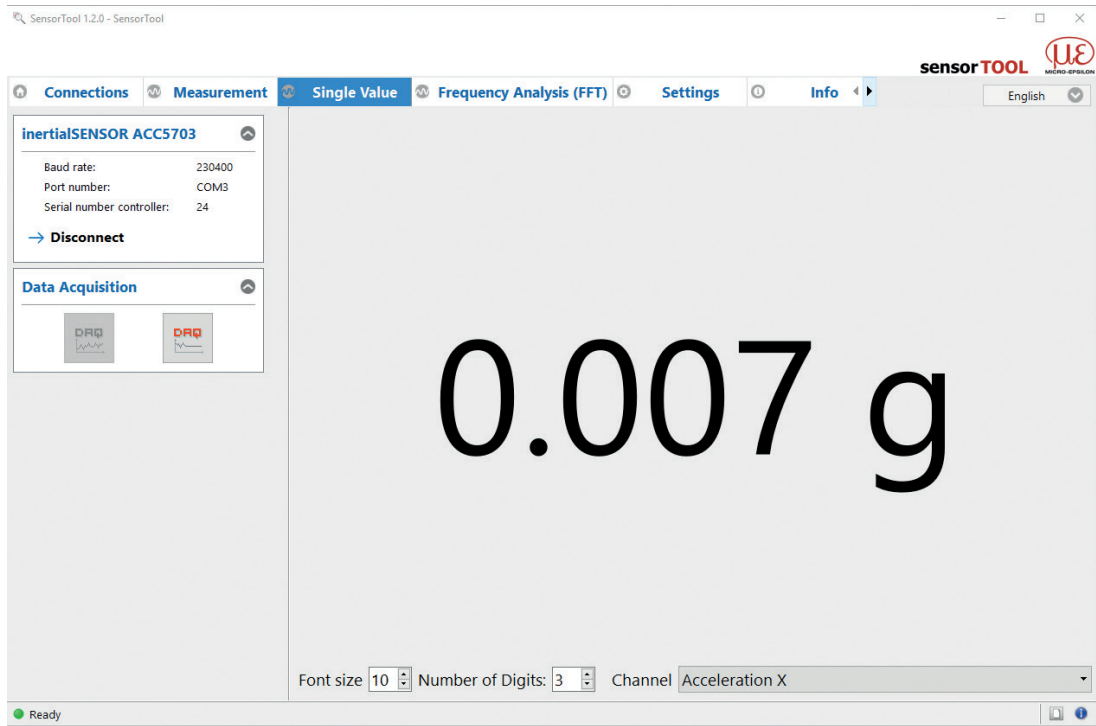

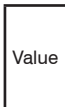

Fig. 26 Single value menu

Single value	Font size	1 ... 30	-	
	Number of digits	0 ... 3	-	
	Channel	Output 1	Selection of the output to be displayed.	
		Output 2	The outputs are set in the <i>Settings</i> menu, see A 3.5.3.	
		Output 3		
		State	Not supported	
		Counter	Not supported	

 Fields with gray backgrounds require a selection.

 Fields with dark border require entry of a value.

A 3.5 Settings Menu

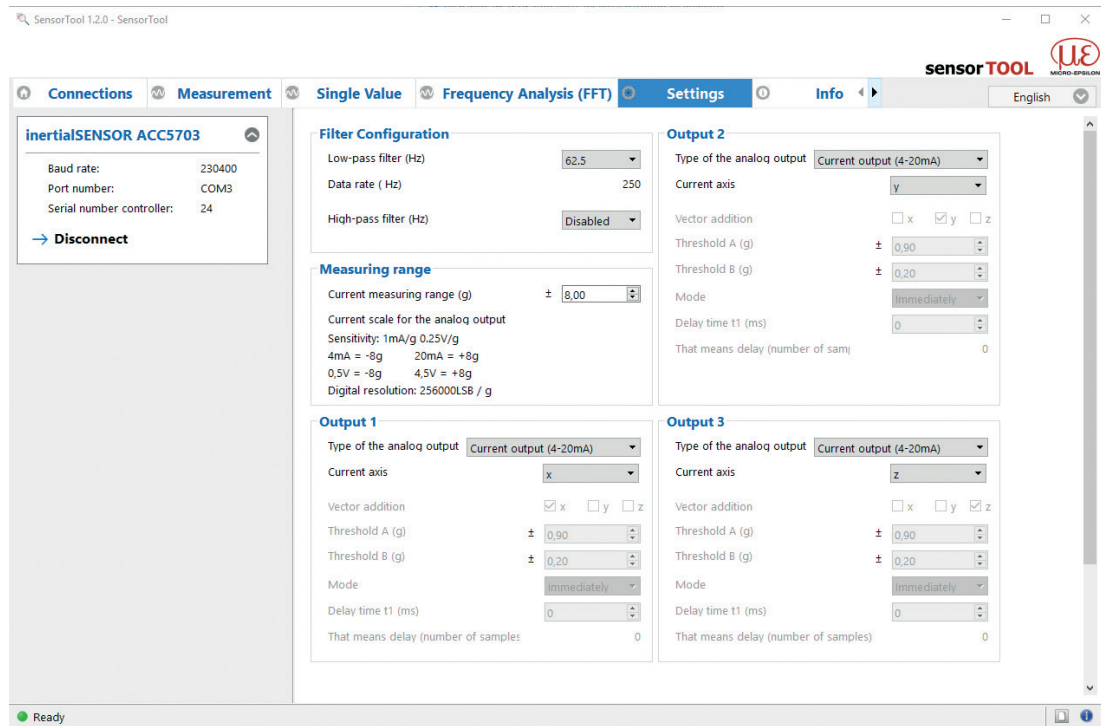



Fig. 27 Settings menu

A 3.5.1 Filter Configuration

Filter configuration	<i>Low-pass filter (Hz)</i>	<i>0,977/ 1,953/ 3,906/ 7,813/ 15,625/ 31,25/ 62,50/ 125/ 250/ 500/ 1000</i>	<i>Set the desired low-pass frequency between 0.977 Hz and 1000 Hz. Specifies the maximum frequency of accelerations that the sensor should still process. The lower the low-pass frequency, the greater the time delay of the measurement signal. The low-pass frequency simultaneously affects the sampling rate of the sensor. The higher the low-pass frequency, the higher the sampling rate (up to 40000 Hz).</i>	
	<i>Data rate (Hz)</i>	<i>Value</i>	<i>The value depends on the settings of the low-pass filter.</i>	
	<i>High-pass filter (Hz)</i>	<i>Disabled</i>		<i>Does not allow frequencies below the set value to flow into the measurement signal. This function is e.g. used to filter out the gravitational acceleration.</i>
		<i>Value</i>		<i>The frequency selection depends on the setting of the low-pass filter.</i>

i With a low pass filter setting of ≥ 500 Hz digital transmission is no longer possible. The measured values are no longer displayed in the software. Only the analog outputs can be used.

 Fields with gray backgrounds require a selection.

 Fields with dark border require entry of a value.

A 3.5.2 Measuring Range

Measuring range

Current measuring range (g) ±

Current scale for the analog output
 Sensitivity: 1mA/g 0.25V/g
 4mA = -8g 20mA = +8g
 0,5V = -8g 4,5V = +8g
 Digital resolution: 256000LSB / g

Fig. 28 Measuring range

Measuring range	Current measuring range	Value	Select measuring range between ± 0.1 g and ± 8 g
	Current scale for the analog output	Value	Display of the current analog output scaling (sensitivity) and the digital resolution.

 Fields with gray backgrounds require a selection.

 Fields with dark border require entry of a value.

A 3.5.3 Output 1, 2, 3

Output 1, 2, 3	Setting options for output		
	Type of analog output	Output off	Output deactivated
		Current output (4 - 20 mA)	Selection of current output 4 - 20 mA
		Voltage output (0.5 - 4.5 V)	Selection of voltage output 0.5 - 4.5 V
Switching output	Setting options, see separate table below		

Output 1, 2, 3	Setting options for switching output				
	Vector addition	x	y	z	Selection of measurement axes (x, y, z) for which a vector addition should be performed.
	Threshold A (g)	Value			Adjustable threshold. Triggers the active switching event when the threshold is exceeded ¹ .
	Threshold B (g)	Value			Adjustable threshold. Triggers the active switching event when the threshold is not reached ² .
	Modus	Immediately			Setting, see 4.4.2
		After time			Setting, see 4.4.2
Delay time t_v (ms)	Value			Setting, see 4.4.2	

- 1) Threshold is not exceeded (not active): low / Threshold is exceeded (active): high
 2) No threshold shortfall (not active): low or high / Threshold is not reached (active): low

 Fields with gray backgrounds require a selection.

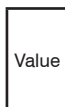
 Fields with dark border require entry of a value.

A 3.6 Info Menu

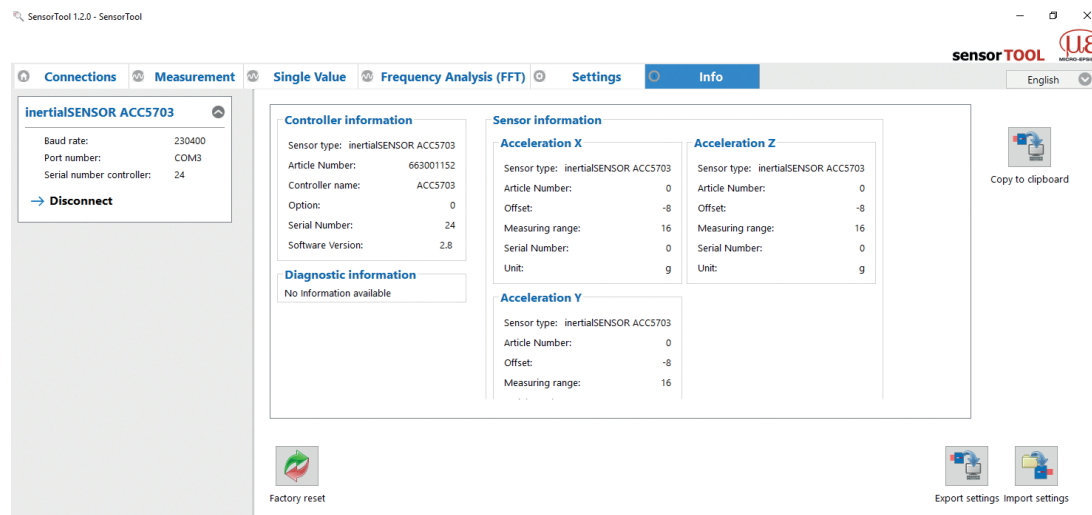

Fig. 29 Info menu view

This window provides the current overview of the sensor Information and diagnostic information.

By clicking the **Disconnect** button you return to the sensor search.

Clicking the **Copy to Clipboard** button copies the information and settings to the clipboard.



Copy to Clipboard

Fig. 30 Copy to Clipboard button

By pressing the `Factory Reset` button, you can restore the factory settings.



Factory Reset

Fig. 31 Factory resetting button

`Export Settings` opens the explorer to store the setting values in a default file `*.csv` on the PC.



Export Settings

Fig. 32 Export settings button



Import Settings

Fig. 33 Import settings button

`Import Settings` opens the explorer and enables loading of the setting values from a stored `*.csv` file.

A 4 Digital Interface RS485

A 4.1 Hardware Interface

The interface is a half-duplex RS485 interface, which means that one cable pair is jointly used for sending and receiving.

Baud rate	230400 b/s
Data format	1 start bit, 8 data bits, 1 parity bit even, 1 stop bit
Bus address	126

Fig. 34 Settings of the RS485 interface

A terminating resistance of 120 Ω is required between the A- and B-line of the RS485 interface at the beginning and the end of the RS485 bus. A terminating resistor of the RS485 line is not incorporated in the sensor. It is therefore allowed to connect several sensors to one bus cable.

A 4.2 Protocol

The sensor acts as RS485 slave. As the system uses a half-duplex protocol, only the master can initiate communication. Each device at the RS485 bus requires its own address. The master sends an enquiry with the destination address to the bus and only the slave with this address answers accordingly.

A 4.2.1 Reading Measurement Data

Master: Request data						
Byte:	SD	DA	SA	FC	FCS	ED
Value:	0x10	x	x	0x4C	x	0x16
				FCS		

Slave: Response data										
Byte:	SD	LE	LE rep	SD rep	DA	SA	FC	Data[]	FCS	ED
Value:	0x68	x	x	0x68	x	x	0x08	x	x	0x16
							FCS			

Designations	
SD	Start Delimiter (0x10: datagram without data, 0x68: datagram with variable length)
LE	Length (number of bytes of Data [] + 3 (DA, SA, FC))
LE rep	LE repeated
SD rep	SD repeated
DA	Destination Address (default 0x7E = 126)
SA	Source Address (e. g. 0x01)
FC	Function Code
FCS	Checksum Request: sum of all bytes with DA, SA and FC; overflow at 256 Response: sum of all bytes with DA, SA, FC and Data; overflow at 256
ED	End Delimiter
Data[]	Measurement data, variable number, little endian

The measurement data consists of

- one status byte,
- one measured values counter (4 bytes),
- number of measured values (1 byte) and
- the measured data.

The measured values counter increases continuously with each sampled value. It represents the number of measured values buffered in the sensor since the last enquiry by the master and therefore represents the number of the measured values transmitted in this package (floats).

A new sampled measurement value is saved to the internal buffer of the sensor. The maximum number of values which can be saved is 19 for each measurement axis. Therefore, an enquiry by the master must reach the sensor within a certain time, that depends on the set sampling rate, in order to read the content from the internal memory and ensure uninterrupted sampling (periodic enquiry).

- Example 1 kHz: 19 values * 1 ms = 19 ms
- Example 250 Hz: 19 values * 4 ms = 76 ms

If the enquiries are not made in time, error flag 0x01 is set in the status byte. The measurement is continued anytime, i.e. the values in the buffer which are not read will be overwritten with updated measurements. The buffer content is, therefore, always updated. The overflow error flag is deleted automatically as soon as the master resumes its periodic enquiries.

The analog output remains unaffected by this. The first measurement value in the Data[] package is the oldest measured value. A measured value is represented as 4-byte float data type in the unit [g]¹.

1) $1 \text{ g} = 9.81 \frac{\text{m}}{\text{s}^2}$

Byte	Meaning	Data format
Data[0]	Status byte (contains error flags, normally 0x00)	8 bit
Data[1]	Long term values counter [bit 0:7] // measured value counter	Uint 32 bit
Data[2]	Long term values counter [bit 8:15]	
Data[3]	Long term values counter [bit 16:23]	
Data[4]	Long term values counter [bit 24:31]	
Data[5]	Number of measured values in this package = [1 ... 19]	8 bit
Data[6]	Padding byte	8 bit
Data[7]	Padding byte	8 bit
Data[8]	Measured value 1 x-axis [bit 0:7]	Float 32 bit
Data[9]	Measured value 1 x-axis [bit 8:15]	
Data[10]	Measured value 1 x-axis [bit 16:23]	
Data[11]	Measured value 1 x-axis [bit 24:31]	
Data[12]	Measured value 2 x-axis [bit 0:7]	
Data[13]	Measured value 2 x-axis [bit 8:15]	
Data[14]	Measured value 2 x-axis [bit 16:23]	
Data[15]	Measured value 2 x-axis [bit 24:31]	
...	...	
Data[83]	Measured value 19 x-axis [bit 24:31]	
Data[n] n=8+(4*Data [5])	Measured value 1 y-axis [bit 0:7]	Float 32 bit
Data[n+1]	Measured value 1 y-axis [bit 8:15]	
Data[n+2]	Measured value 1 y-axis [bit 16:23]	
Data[n+3]	Measured value 1 y-axis [bit 24:31]	

Byte	Meaning	Data format
Data[n+4]	Measured value 2 y-axis [bit 0:7]	Float 32 bit
Data[n+5]	Measured value 2 y-axis [bit 8:15]	
Data[n+6]	Measured value 2 y-axis [bit 16:23]	
Data[n+7]	Measured value 2 y-axis [bit 24:31]	
...
Data[n+m] m=4*Data[5]	Measured value 1 z-axis [bits 0:7]	Float 32 bit
Data[n+m+1]	Measured value 1 z-axis [bits 8:15]	
Data[n+m+2]	Measured value 1 z-axis [bits 16:23]	
Data[n+m+3]	Measured value 1 z-axis [bits 24:31]	
...

Fig. 35 Encoding of Measured Data in the Transmission Protocol

A 4.2.2 Example Transmission of a Measurement Value

Master: Request data						
Byte:	SD	DA	SA	FC	FCS	ED
Value:	0x10	0x7E	0x01	0x4C	0xCB	0x16
FCS						

DA = Destination Address = $0x7E = 126_{10}$ (slave address)

SA = Source Address = $0x01$ (master address)

FCS = Checksum = $0x7E + 0x01 + 0x4C = 0xCB$
 $= 126 + 1 + 76 = 203$ (no overflow) at 256)

Slave: Response data										
Byte:	SD	LE	LE rep	SD rep	DA	SA	FC	Data[]	FCS	ED
Value:	0x68	1B	1B	0x68	0x01	0x7E	0x08	x	0x67	0x16
					FCS					

LE = Length(data) + 3 = Length(16 byte measurement values + 1 byte status + 4 byte counter + 1 byte number) + 2 byte padding) + 3 = 27

DA = Destination Address = $0x01$ (Master)

SA = Source Address = $0x7E = 126_{10}$ (Slave)

FCS = Checksum = $0x01 + 0x7E + 0x08 + 0x00$ (status) + $0x04$ (counter) ...
 $= 0x67$ (note overflow at 256 each time = reset sum to zero)



Micro-Hybrid Electronic GmbH
Heinrich-Hertz-Str. 8 · 07629 Hermsdorf / Germany
Tel. +49 36601 592100
contact@microhybrid.com · www.microhybrid.com